

Model RSH-2100 Series Radiant Heated Transport Cabinet



Performance Features

- **Gentle Touch™** *Radiant Heat Hold* produces unsurpassed holding times
- Designed for safe and secure transport of product from one location to another
- 24 hour (or longer) holding capability for all types of meats
- Induces optimum enzyme action to naturally tenderize or "age" meats
- Delivers more flavorful, tender, and juicier meats
- Superior holding capability allows for banquet preparation well in advance of serving time
- Maintains just cooked appearance and flavor in excess of reasonable holding times
- Hold temperature range: 75F – 200F

Construction Features

- Self-contained power module for ease of service
- Removable twist lock cord set
- Fully insulated construction
- Type 304 welded stainless steel body
- 12 gauge stainless steel internal frame for strength
- Field reversible doors
- Latch is magnetic/mechanical style with key lock
- Long lasting, high temperature silicone door gasket
- Four heavy duty, 5" swivel casters, two with brakes
- Full perimeter bumper
- Transport latch
- Lift out oven interior for easy cleaning
- Radiant heat source in side walls for superior holding and serviceability



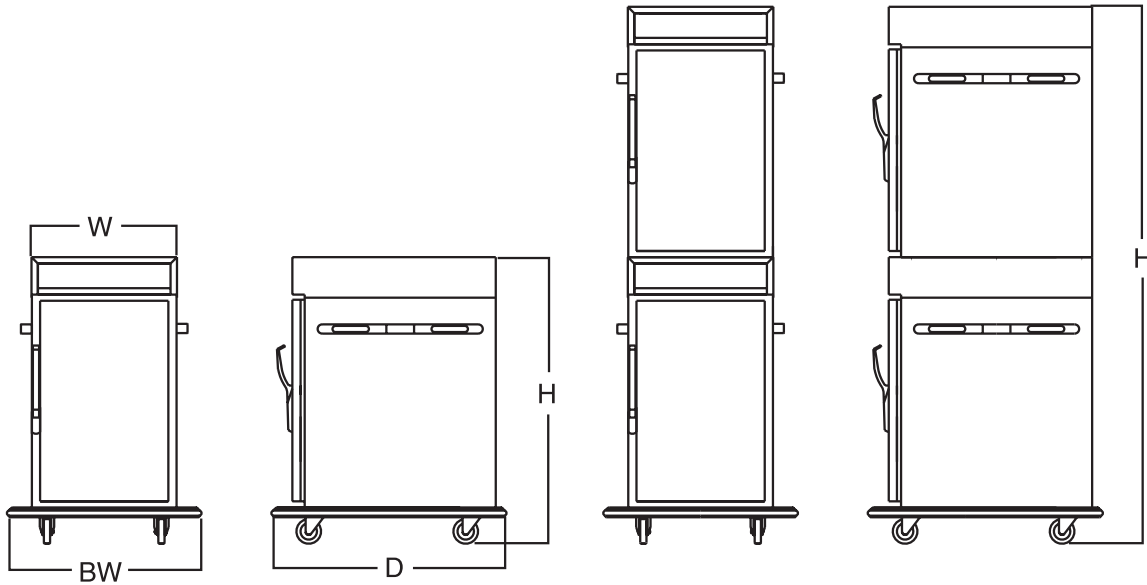

Model Number	Standard Pan Capacity Per Cabinet			Height (H)	Depth (D)	Width (W)	Base Width (BW)	Shipping Wt. (lbs)	Volts	Total Watts Per Cabinet	Amps Per Cabinet	Hertz/Phase	Power Cord Plug (NEMA)								
	18x26x1 Sheet	12x20x2 1/2 Pan	13x26x2 5/8 Basket																		
RSH-2104	4	8	-	36	33 ³ / ₈	26 ¹ / ₈	22 ¹ / ₂	197	120	1000	8.6	50/60 Single Phase	5-15P								
RSH-2104 Stacked				67 ¹ / ₈				394													
RSH-2106	6	12	-	41 ¹ / ₂				33 ³ / ₈						26 ¹ / ₈	22 ¹ / ₂	246	120	1000	8.6	50/60 Single Phase	5-15P
RSH-2106 Stacked				78 ¹ / ₈												492					

Bidding Specifications

Royalton Model # RSH-21___ (Stacked), gentle radiant heated transport cabinet, fully insulated, all stainless steel construction with in-wall radiant heating and solid-state controls incorporated in the self-contained power module. Digital temperature readout.

Options

- Correctional Package
- Casters – Specials and Sizes
- Push-Pull Handles
- Shelving – Wire Rack

Accessories

- Cold Pack
- Wire Rack
- Stacking Kit
- Universal Slides